

CYLINDER RECOVERY TRANSPORT VESSEL **GASTOR S**

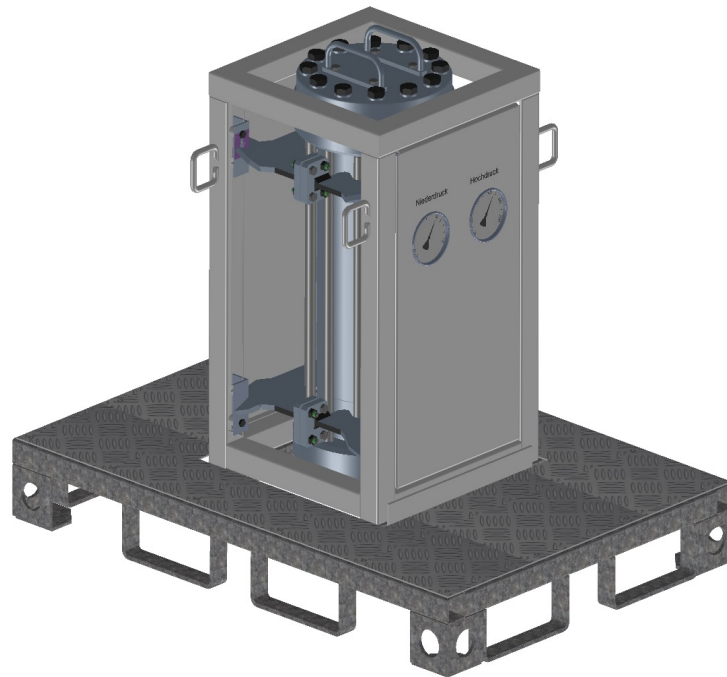

Emergency Response Recovery Vessel

Containment and Transport of Damaged Gas Cylinders

Transport of defective gas cylinders with a wide variety of different gases with ADR, RID and IMDG approval. On request also with US DOT approval. For approved list of gases see compatibility list D/BAM/DG-06-126/S. Also approved for Acetylene gas cylinders.

See several other sizes of the GASTOR Safety Container product line.
Custom design and production according to client specific requirements.

Technical Specification – GASTOR S

- Building Regulation: ATR D1/16
- Test Pressure PH: 225 bar
- Volumetric capacity: 18 liters
- Maximum Product Bar x liter: 2.700
- Diameter inside: 170 mm
- Length inside: 640 mm
- Length outside: 1.150 mm
- Width outside: 800 mm
- Height outside: 990 mm
- Tara Weight: 257 kg
- Maximum Total Weight: 340 kg

A **PARTNER** FOR **SAFETY SOLUTIONS**



CUSTOMIZED **SOLUTIONS** FOR YOUR **SAFETY**

GASTOR Safety Containers are available in various sizes.

CYLINDER RECOVERY VESSEL

GASTOR XS | GASTOR S | GASTOR M | GASTOR L | GASTOR XL

ROOM FOR YOUR **IDEAS**



Please contact us with your specific needs or for our safety solutions:

■ TRANSPORT AND STORAGE CONTAINER FOR LIQUIDE MERCURY:
QC 80 | QC 150 | SC900

■ REMOTE CONTROLLED SALVAGE SYSTEM
ROSS

■ TRANSPORT CONTAINER FOR EXPLOSIVES AND CHEMICAL WARFARE AGENTS
EXPLO

